



HARWIN

Component Specification

C01312

2.00mm Pitch Jumper Sockets
November 2022

SECTION	TITLE	PAGE
1	Description of Connector and Intended Application	2
2	Ratings	2
Appendix 1	Gauges	3

1. DESCRIPTION OF CONNECTOR AND INTENDED APPLICATION

A range of 2mm pitch jumper sockets, consisting of a moulded outer body holding phosphor bronze spring contacts. The contacts are either tin plated overall, or selectively gold plated on the contact area. The component is intended to interconnect two adjacent 0.50mm square or round section pins on 2mm pitch centres. Connectors can be mounted side by side in either direction on 2mm pitch centres.

2. RATINGS

2.1. Electrical Characteristics

Current Rating, 25°C ambient.....	2A max
Working Voltage (at sea level).....	250V DC nominal or AC peak
Voltage Proof (at sea level).....	500V rms at 50Hz
Contact Resistance:	
Initial.....	20mΩ max Tin, 15mΩ max Gold
After conditioning.....	25mΩ max Tin, 20mΩ max Gold
Insulation Resistance (measured between two pins not electrically connected):	
Initial.....	1,000MΩ min
Hot after conditioning.....	100MΩ min

2.2. Environmental Characteristics

Environmental Classification.....	40/85/21
Operating Temperature Range.....	-40°C to +85°C
Low Air Pressure Severity.....	300 mbar

2.3. Mechanical Characteristics

Durability:	
Gold on contact area.....	300 mating operations
Tin on contact area.....	50 mating operations
High Temperature, Long Term (current as in 2.1.).....	1,000 hours at 70°C
High Temperature, Short Term (no electrical load).....	250 hours at 85°C
Clip Retention in Housing.....	5.0N min
Insertion force (using gauges shown in Appendix 1).....	10.0N max
Withdrawal force (using gauges shown in Appendix 1).....	1.0N max

APPENDICES NOTES:

1. All dimensions are in millimetres.

APPENDIX 1 – GAUGES

NOTES:

1. Material = Steel to BS1407 or equivalent.
2. Gauging surfaces to be hardened/ground, 650 HV5 min.
3. These gauges to be used for testing fully assembled components only.
4. Ultimate wear limit 0.005mm is allowable on gauging dimensions.

A1.1. Insertion and Withdrawal Gauge

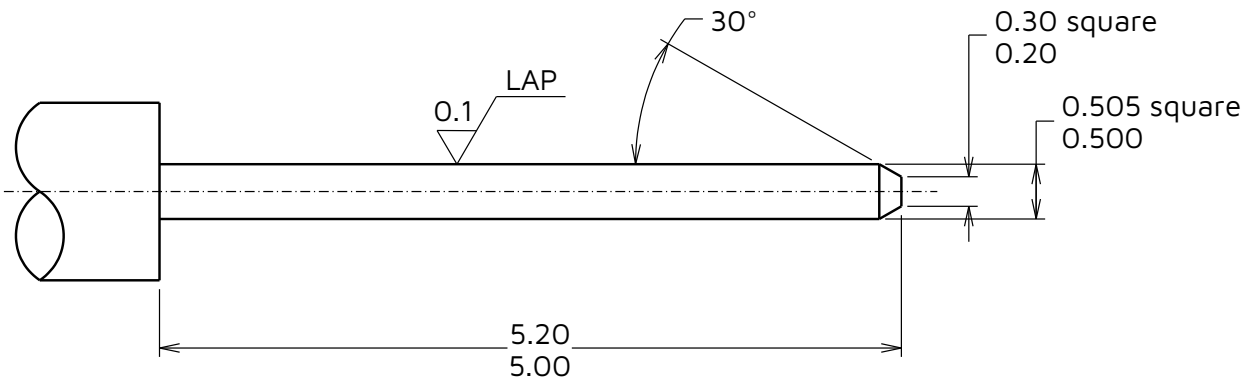

A1.2. Holding Gauge

