

Datamate Mix-Tek Assembly and Contact Removal

CABLE ASSEMBLY TO POWER CONTACTS

1. Ensure that the wire to be soldered is within the specified size for the contact. Failure to use the specified wire size will result in a poor-quality solder joint.

Gender	Contact	Wire Gauge (AWG)	Minimum Strip Length
Female	M80-325	12	5.00mm
	M80-326	14	
	M80-327	16	
	M80-328	18	
	M80-329	20	
	M80-32A	12	
	M80-32B	14	
	M80-32C	16	
	M80-PF5	10	
Male	M80-PM5	10	5.00mm
	M80-335	12	
	M80-336	14	
	M80-337	16	
	M80-338	18	
	M80-339	20	

2. Cut the end of the cable to be terminated so that there is a clean-cut end. Strip the cable to the correct length (Figure A). We recommend that when the wire is stripped, it is clamped or supported close to the stripping area - this will prevent insulation slippage. Suitable wire strippers (such as a PTFE wire strippers) must be used. This should result in all the strands lying together neatly. If the lay of the strands is disturbed, it may be re-imposed with a slight twist.

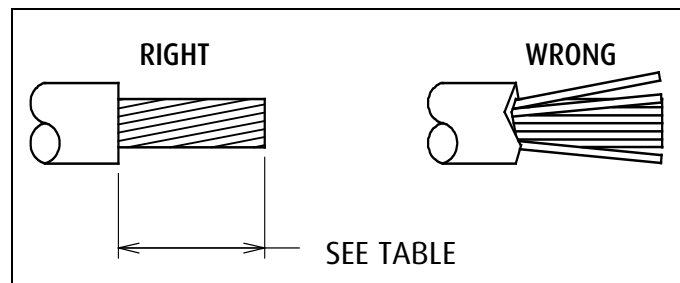

Figure A: Wire strip

3. Coat the stripped portion of the wire in flux and insert the wire into the contact.
4. Secure the contact and insert the wire into the solder cup ensuring the conductor is bottomed out at the base of the solder cup.
5. Using a soldering iron, heat the wire and solder cup and feed solder into the open areas, allow the solder to flow into the cup until it is filled, but not overfilled.

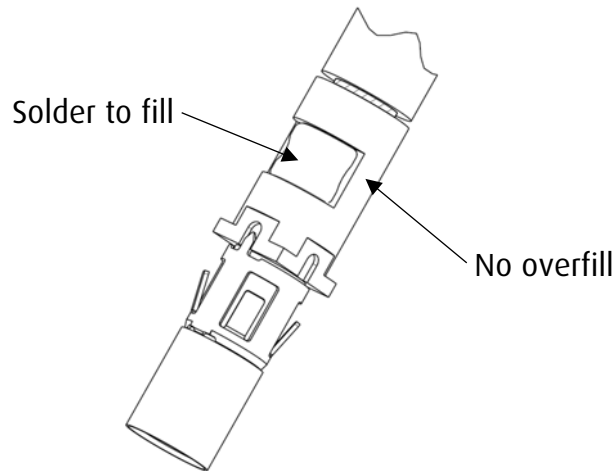

Figure B: Contact and wire assembly

6. Clean the soldered contacts with a suitable alcohol and water wash to remove solder and flux residue.

CABLE ASSEMBLY TO COAX CONTACTS

For wire to contact assembly of **COAX** contacts, please see **IS-34 - HAND CRIMP TOOLS Z80-292 & Z80-293**.

Harwin North America

T: +1 603 893 5376

E: mis@harwin.com W: www.harwin.com

Harwin Europe

T: +44 (0) 23 9231 4545

E: mis@harwin.co.uk W: www.harwin.com

Harwin Asia

T: +65 6 779 4909

E: mis@harwinasia.com W: www.harwin.com

CONTACT ASSEMBLY INTO HOUSING

1. Before assembly ensure that the retention collar is oriented correctly, with the retention tangs aligned with the corners of the square.

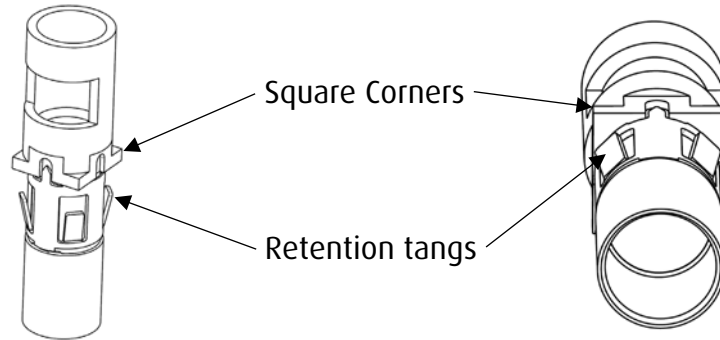

Figure C: Correct collar orientation

2. Take the wire and contact assembly and insert into the back end of the housing, ensuring that the contact square is lined up with the housing, and the contact is not at an angle to the housing cavity. The contact should move freely into the housing until the back of the solder cup is around 1-2mm from the back of the housing, where resistance will be felt.

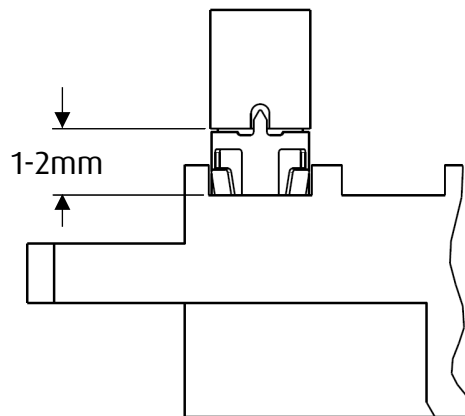

Figure D: Contact insertion resistance position

3. Gently push on the wire until you can feel / hear that the contact collar has engaged within the housing. The back square section of the contact should sit flush with the lower walls of the housing once fully inserted.

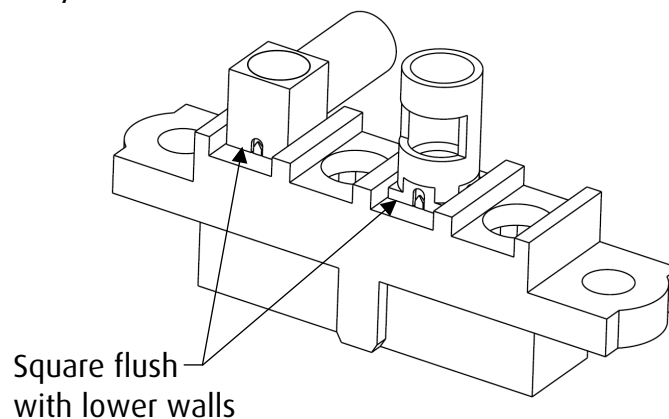

Figure E: Contacts pushed to depth

Harwin North America

T: +1 603 893 5376

E: mis@harwin.com W: www.harwin.com

Harwin Europe

T: +44 (0) 23 9231 4545

E: mis@harwin.co.uk W: www.harwin.com

Harwin Asia

T: +65 6 779 4909

E: mis@harwinasia.com W: www.harwin.com

CONTACT REMOVAL FROM HOUSING

1. Insert Z80-290 contact removal tool into the mating end of the cable housing, making sure the tips are oriented to the corners of the housing opening, and are outside of the contact. Push slightly on the rear of the contact while inserting the tool (this helps properly engage over the retention tabs internally).

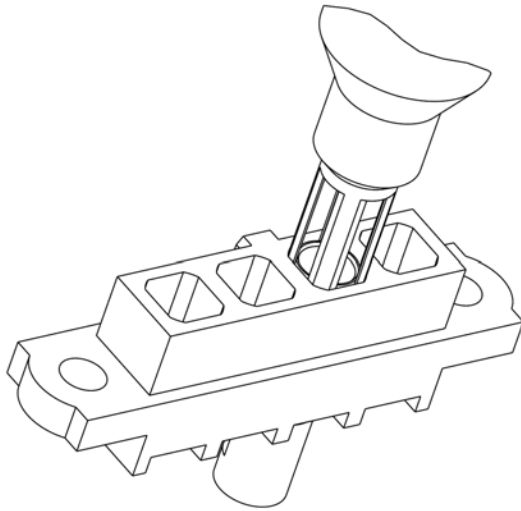

Figure F: Prongs correctly oriented

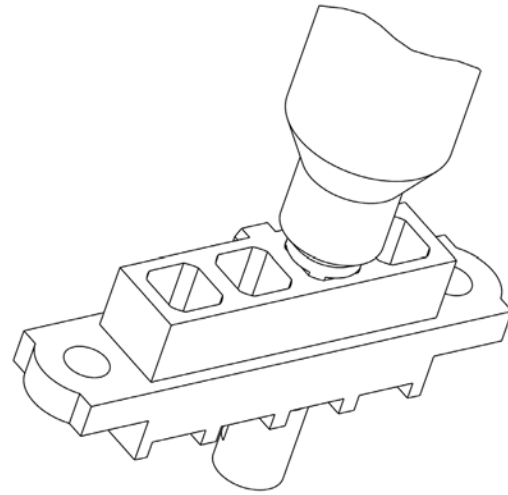

Figure G: Tool pushed to depth

2. Push the tool to depth, the prongs should be mostly inside the housing.
3. Gently pull back on the contacts wire and completely remove the contact from the assembly.

REMOVAL TOOL MAINTENANCE

While it is possible to bend back the tool heads prongs if damaged in use, it is recommended that if the tool prongs show signs of permanent set that a new tool is purchased.

If you have any questions about this instruction sheet, or the Datamate range of connectors, please contact technical@harwin.com.

APPENDIX 1 – DOUBLE-ENDED WIRE LENGTH RECOMMENDATIONS

Assembly of double-ended cables can prove difficult if the wires are of a short length due to the gauge of special contact wires. Final orientation should be considered and accounted for during assembly of the contacts to the wires.

We recommend that customers attempt to design using lengths 75 times greater than the gauge diameter although shorter lengths are possible.

If your application requires shorter wires, then we recommend that trial cables be assembled prior to production scaling.

APPENDIX 2 – RETENTION COLLAR ADJUSTMENTS

Retention collar tabs can accidentally be flattened during the assembly process.

If this occurs, the tangs can be gently lifted. This can be accomplished using a small flathead screwdriver.

Harwin North America

T: +1 603 893 5376
E: mis@harwin.com W: www.harwin.com

Harwin Europe

T: +44 (0) 23 9231 4545
E: mis@harwin.co.uk W: www.harwin.com

Harwin Asia

T: +65 6 779 4909
E: mis@harwinasia.com W: www.harwin.com